

SPD 360 C+

SPD 360 CDH

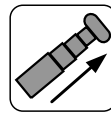

3960 lbs



8'6" - 27'11"

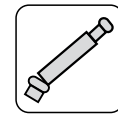

6'11" - 11'2"

	SPD360C+: 5280 lbs SPD360CDH: 5060 lbs	-	2T-D7: 22 lbs	JIB600M: 220 lbs
SPD360C+				
SPD360CDH				
<p>Engine: 3 cylinders water cooled diesel, KUBOTA mod. D722-E3B, 2 rpm levels, EPA TIER 4 : 3 cilindri diesel raffreddato a liquido, KUBOTA mod. D722-E3B, 2 livelli di regime, EPA TIER 4 : Wassergekühlter 3 Zylinder Diesel Motor, KUBOTA mod. D722-E3B, 2 rpm, EPA TIER 4 : Diesel 3 cilindros con refrigeración por aire, KUBOTA mod. D722-E3B, 2 niveles rpm, EPA TIER 4 : Diesel 3 cylindres, refroidissement à eau, KUBOTA mod. D722-E3B, accélérateur à 2 niveaux, EPA TIER 4</p>				
<p>Telescopic Boom: 1 base and 4 telescopic sections high-tensile structural steel. All sections synchronized and full power. : 1 braccio principale e 4 telescopici in acciaio strutturale ad alta resistenza. Sfilo completamente idraulico e sincronizzato. : 1 Hauptausleger + 4 Hochwiderstand Stahl Teleskopausleger. Voll hydraulischer und teleskopierbarer Ausleger. : 1 pluma principal y 4 telescópicas en acero de alta resistencia. Elementos sincronizados e hidráulicos. : 1 flèche principale et 4 télescopiques en acier à haute résistance. Éléments synchronisés et hydrauliques.</p>				

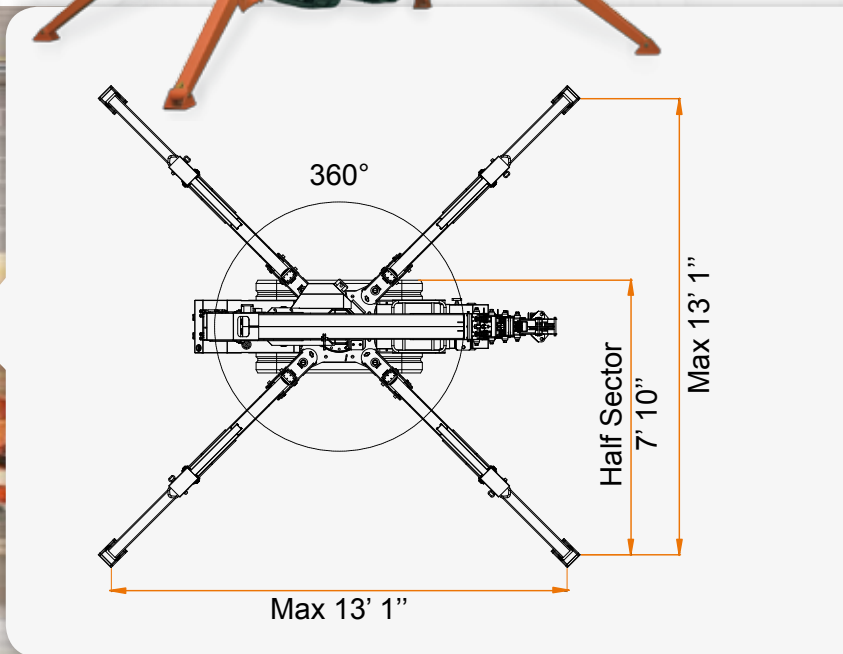
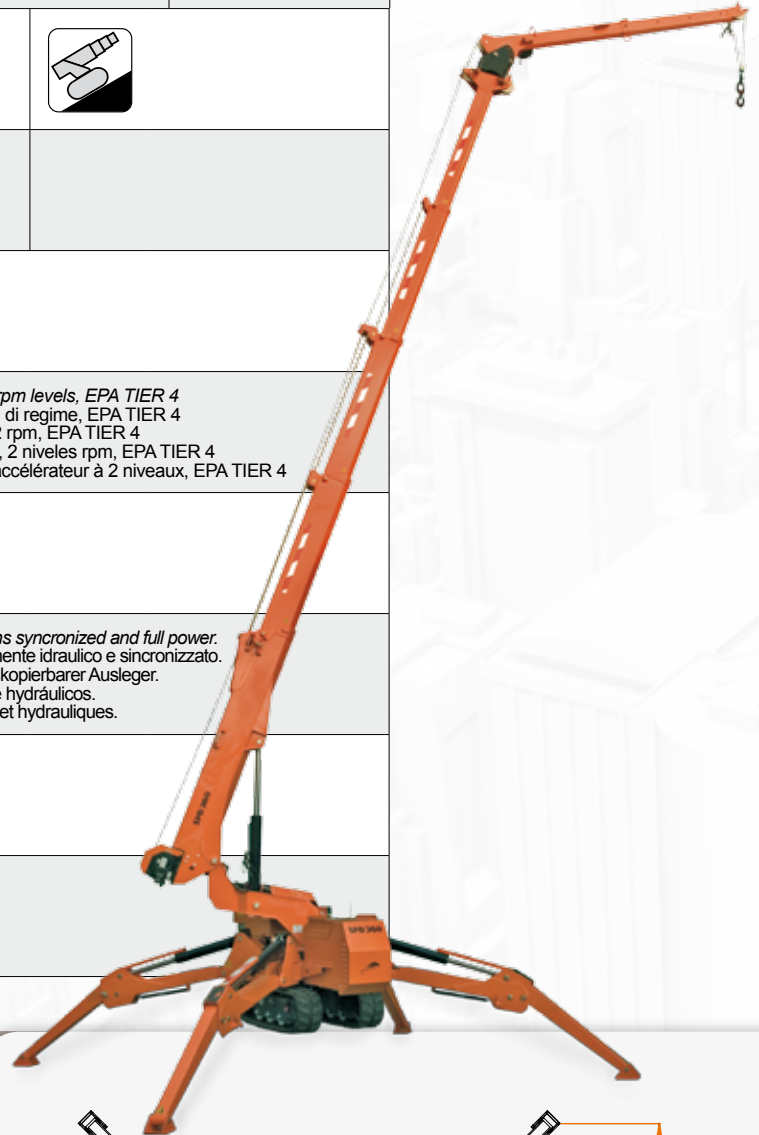

SPD 360 C+

SPD 360 CDH

